

The Micromag HP/80 follows on from the standard Micromag and has all of the same incredible benefits. This unit was developed to suit high pressure through spindle coolant applications, where the smallest of particles can damage seals, spindles and even the efficiency of the cutting tool.

Micromag HP/80 can be installed anywhere in the fluid delivery system and will ensure that even sub micron magnetic and paramagnetic particles are removed before they can cause any expensive damage.

For further information relating to the benefits and operation please refer to the supplied standard Micromag brochure.

Cleaning

Using the supplied cleaning tool, a fully contaminated core can be cleaned in under 30 seconds! Leaving you with only the metallic particles, which can be easily disposed of, no dirty cartridges!



Suitable Products

Neat & soluble oils.

Installation Location

Pre or post pump, delivery line, spindle feed or pre membrane cartridge.

Benefits

- High pressure rated
- Sub micron filtration
- Large holding capacity
- High intensity Rare Earth magnetic material
- Full Stainless Steel construction
- Suitable for all machining applications
- Environmentally ethical
- No consumables

Category

High Pressure.



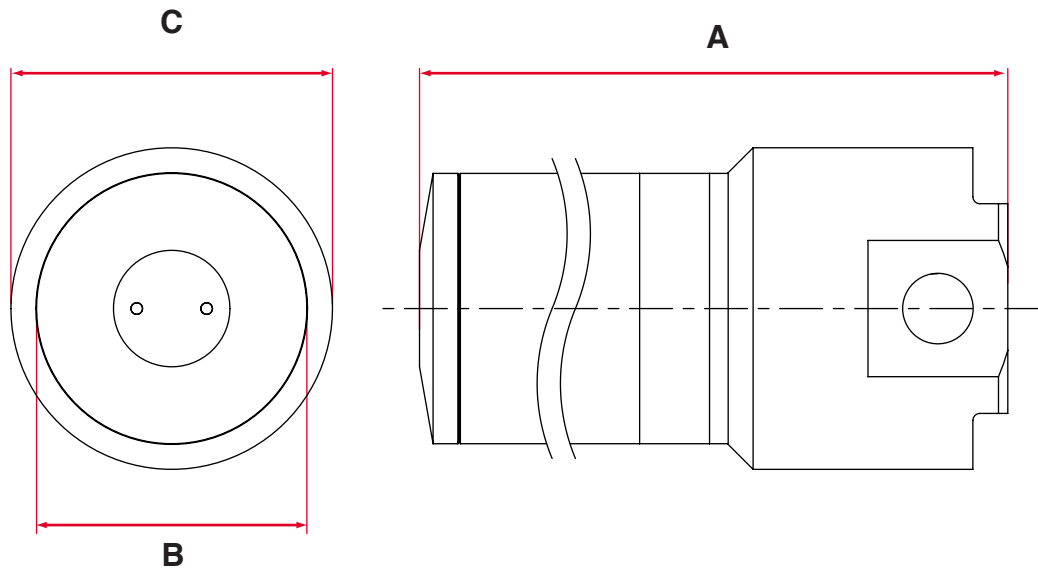

Product Information

Product number	Flow rate ltrs/min.	Contamination capacity kgs	Max. operating pressure bar	Connection " BSP	Temperature range °C	Weight Kgs	Construction	Dimensions mm		
								A	B	C
MM5/HP/80	70	1	80	1	0 – 140	18	Full stainless steel construction	247	116	125
MM10/HP/80	100	2	80	1	0 – 140			365	116	125
MM20/HP/80	150	4	80	1½	0 – 140	33		625	116	125

Performance

Maximum Pressure	80 Bar
Magnetic Performance:	High Intensity
Circuit Design:	Open
Magnetic Material:	Rare Earth Neodymium Iron Boron
Magnet Grade:	N45 – Inspected & confirmed via hystergaph prior to use
Temperature:	0°C - 140°C

Materials

Housing:	316 Grade Stainless Steel
Lid:	316 Grade Stainless Steel
Tube:	316 Grade Stainless Steel – Aerospace Quality
Seal:	Viton rubber

If you have any more questions, require technical assistance or would like a quotation, please contact us.

www.eclipsemagnetics.com

Eclipse Magnetics Ltd, Atlas Way, Sheffield, S4 7QQ, England
 T +44 (0)114 225 0600 F +44 (0)114 225 0525 E info@eclipsemagnetics.com W www.eclipsemagnetics.com

While every effort has been made to ensure the accuracy of the information in this publication please note that specifications may change without notice.



FM31278